

# FLT3 Mutation Assays



## Background

Mutations in the *fms* related tyrosine kinase 3 (*FLT3*) gene are the most common mutations found in acute myeloid leukemia (AML), occurring in approximately 30% of patients at the time of diagnosis, and are characterized by an aggressive phenotype with a high prevalence of relapse<sup>1,2</sup>.

The most prevalent and clinically significant type of *FLT3* mutation is an internal tandem duplication (ITD) in the juxtamembrane domain<sup>3</sup>. Many clinical studies have found that *FLT3* ITD mutations are associated with higher concentrations of leukemic cells in both blood and bone marrow, increased incidence of relapse, and decreased overall survival.

The second most common mutation type in the *FLT3* gene is a tyrosine kinase domain (TKD) point mutation in aspartate (D835) or isoleucine (I836). TKD mutations result in constitutive autophosphorylation and activation of *FLT3*<sup>2,4,5</sup>. TKD mutations have been linked to poor overall survival, but to a lesser extent as compared to ITD mutations.

Currently there are several small molecule inhibitors of *FLT3* in clinical trials.

## Method

This assay targets genomic DNA of both the immunoglobulin-like juxtamembrane (JM) domain, known to harbor ITD mutations, and the second half of the interrupted kinase (TK2) domain, known to harbor D835 mutations.

Detection of ITD mutations is determined by the increased size of the PCR products (larger than 330 bp) compared to the product produced by wild-type genes.

Detection of D835 mutations requires enzymatic digestion with *EcoRV* (not included). After digestion, the wild-type *FLT3* gene

will produce three products (21, 49, and 80 bp in size). D835 mutants lose a restriction site and produce two products (130 and 21 bp).

Three master mixes are included in this assay; the ITD, D835, and a Specimen Control Size Ladder. The Specimen Control Size Ladder is used to ensure the quantity and quality of input DNA is adequate to yield a valid result. This master mix targets multiple genes and generates a series of amplicons (100, 200, 300, 400, and 600 bp).

This assay is designed to work with all standard DNA extraction methods.

PCR products can be analyzed by capillary electrophoresis with use of ABI instruments or standard agarose TBE gel electrophoresis with ethidium bromide staining.

## Specimen requirements

1. 5 cc of peripheral blood, bone marrow biopsy, or bone marrow aspirate anti-coagulated with heparin or EDTA; or,
2. Minimum 5 mm cube of tissue; or,
3. 2 µg of genomic DNA; or,
4. Formalin-fixed, paraffin-embedded tissue or slides.

## References

1. *NEJM*. 2013; 368(22): 2059-74
2. *Blood*. 2002; 99(12): 4326-35.
3. *Expert Opin. Ther. Targets*. 2015; 19(1): 37-54
4. *Blood*. 2001; 97:2434-2439.
5. *Leukemia*. 2005; 19 (8): 1345-1349.

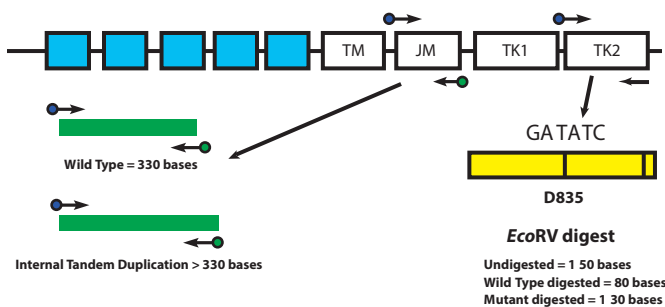

**Figure Legend:** The schematic is a simplified representation of the genomic organization of the *FLT3* gene and the relative positions of the assay primers that target the juxtamembrane (blue) and kinase (white) domains.

## Reagents

Controls	Concentration	Units in 33 Reaction Assay	Units in 330 Reaction MegaKit
IVS-0017 Clonal Control DNA	200 µg/mL	1 x 100 µL tube	5 x 100 µL tubes
IVS-P001 Clonal Control DNA	200 µg/mL	1 x 100 µL tube	5 x 100 µL tubes
IVS-0000 Polyclonal Control DNA	200 µg/mL	1 x 100 µL tube	5 x 100 µL tubes
Master Mixes	Target	Units in 33 Reaction Assay	Units in 330 Reaction MegaKit
<i>FLT3</i> ITD Master Mix	<i>FLT3</i> ITD	1 x 1500 µL tube	10 x 1500 µL tubes
<i>FLT3</i> D835 Master Mix	<i>FLT3</i> TKD	1 x 1500 µL tube	10 x 1500 µL tubes
Specimen Control Size Ladder	Multiple Genes	1 x 1500 µL tube	10 x 1500 µL tubes

## Gel electrophoresis detection

Data was generated using the *FLT3* ITD Master Mix and amplified products were run on a 2% agarose TBE gel. Lane 1 is a *FLT3* ITD control\*; lane 2 is a 10% dilution of a *FLT3* ITD control; and lane 3 is IVS-0000, which is representative of a WT product. A standard 100 bp DNA size ladder was run in the lanes flanking the test samples.

\*IVS-0050 performs comparable to IVS-0017 clonal control DNA, which is included in the kit as the positive control.

### *FLT3* ITD Master Mix

Lane 1 = 100% IVS-0050  
Lane 2 = 10% IVS-0050  
Lane 3 = 100% IVS-0000

Mutant: 360 bp →  
Wild Type: 330 bp →

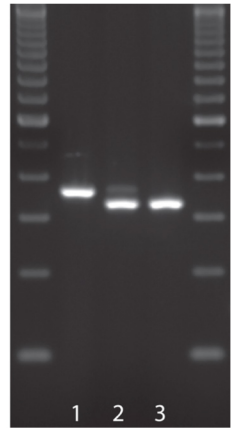

## Capillary electrophoresis detection (ABI)

Data was generated using the *FLT3* ITD Master Mix and amplified products were run on an ABI 3100 instrument. Panel 1 is the recommended *FLT3* ITD positive control; panel 2 is data generated testing a 10% dilution of the positive control; and Panel 3 is IVS-0000, which is representative of a WT product.

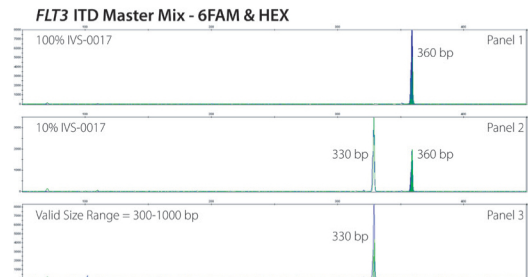

## Ordering information

Catalog #	Products	Quantity
1-412-0010	<i>FLT3</i> Mutation Assay - Gel Detection	33 reactions
1-412-0020	<i>FLT3</i> Mutation Assay MegaKit - Gel Detection	330 reactions
1-412-0031	<i>FLT3</i> Mutation Assay - ABI Fluorescence Detection	33 reactions
1-412-0041	<i>FLT3</i> Mutation Assay MegaKit - ABI Fluorescence Detection	330 reactions

These products are intended **For Research Use Only**. Not for use in diagnostic procedures.

### Distributed by:



50 Valleywood Drive  
Markham, Ontario L3R 6E9  
800.387.9643  
800.268.1150 Français  
905.470.2381 Fax  
[inter-medico.com](http://inter-medico.com)

*FLT3* internal tandem duplication testing is covered by United States Patent number 6,846,630 and 8,178,292 and European Patent number 0959132, licensed exclusively to Invivoscribe Technologies (except as validated in France and the United Kingdom, where the respective national parts of the EP patent are exclusively licensed to the Invivoscribe® subsidiary LabPMM GmbH)

Use of this product may require nucleic acid amplification methods such as Polymerase Chain Reaction (PCR). Any necessary license to practice amplification methods or to use amplification enzymes or equipment covered by third party patents is the responsibility of the user and no such license is granted by Invivoscribe Technologies, Inc., expressly or by implication.

For additional patent information, contact our legal department by email at [legal@invivoscribe.com](mailto:legal@invivoscribe.com), or by telephone in the United States: 1 (858) 224-6600.

REV A MARCH 2017